

# A LIFE THAT BRINGS ALL JOYS CLOSER TO YOU

The bond of a  
healthy life,  
closer to you



The convenience  
of work places,  
closer to you



The thrill of an  
entertaining life,  
closer to you



The canvas of  
world-class  
education,  
closer to you



**HAPPENING**  
**HADAPSAR**  
CLOSER  
TO LIFE

The therapy  
of shopping blues,  
closer to you



The warmth of  
global cuisines,  
closer to you



- 
- **ELEVATED RECREATIONAL ZONE**
  - **2 LARGE FUNCTION HALLS**
  - **2 FLOOR CLUB HOUSE**
  - **BADMINTON COURT**
  - **4 GUEST ROOMS**
  - **PARTY LAWN**



IMAGES ARE FOR REPRESENTATION PURPOSE ONLY

- MULTIPURPOSE COURTS • JOGGING TRACK • SKATE RINK • PET PARK
- GIANT CHESS BOARD



- **2 TENNIS COURTS WITH ACADEMY**
- **HALF BASKETBALL COURT**
- **COMMUNITY GARDEN**
- **MULTISPORT COURT**
- **BADMINTON COURT**
- **KIDS PLAY AREA**
- **OUTDOOR GYM**

# 20+ AMENITIES SPREAD ACROSS 90,000 SQ.FT. ELEVATED PODIUM



Futsal Court



Kids Play Area



Business Centre



Outdoor GYM



Indoor GYM



Tennis Court



Swimming pool



Mini Theatre



Jogging Track



Games Room

HAPPENING  
ADAPTSAR  
CLOSER  
TO LIFE



Skate Rink



Pet Park



Community Gardening



# UNVEILING NEW TOWER AT HAPPENING HADAPSAR

**2 & 3 BHK  
DELIGHTFUL HOMES**



# FOREVER VIBRANT VIEW OF SEASONS MALL

**EXCLUSIVE  
2 BHK DELIGHTFUL HOMES**





# FOREVER VIBRANT VIEW

**3 BHK  
DELIGHTFUL HOMES**



# ABUNDANT SUNLIGHT & AMPLE VENTILATION

2 & 3 BHK  
DELIGHTFUL HOMES

EAST - WEST FACING  
BALCONY



# PRIME LOCATION FROM THE PROJECT ENTRANCE & BUSINESS CENTRE

2 & 3 BHK  
DELIGHTFUL HOMES



# 2 & 3 BHK DELIGHTFUL HOMES



# CLOSER TO THE PINNACLE, OF EXPONENTIAL APPRECIATION

CODENAME  
**FIREWORKS**  
**13%**

PRE -  
2000

2000-2005

BIRTH OF  
MAGARPATTA CITY

2005-2012

THE RISE OF  
COMMERCIAL  
ESTABLISHMENTS

2012-2017

THE ESTABLISHMENT  
OF AMANORA AND  
SP INFOCITY  
TOWNSHIP AS WELL  
AS RETAIL  
INFRASTRUCTURE

2017-2019

HOUSING  
SHORTAGE  
BROUGHT ON BY  
INADEQUATE  
INFRASTRUCTURE  
DEVELOPMENT  
PLANS

2019-2021

INFRASTRUCTURAL  
ANNOUNCEMENTS  
INVOLVING THE  
RING ROAD, THE  
METRO RAIL AND  
PURANDAR  
AIRPORT

2021-2022

FIREWORKS HAS  
EXPERIENCED  
APPRECIATION OF  
OVER AND ABOVE  
MARKET AVERAGE,  
SINCE IT'S LAUNCH  
IN DECEMBER 2021

2021-2025

WITH THE FAST  
GROWING  
CONNECTIVITY,  
HADAPSAR IS  
PROJECTED AS A  
NODAL HUB WHICH  
IS EXPECTED TO  
APPRECIATE BY 85%

It's time to bring alive the  
amazing experience called

**HAPPENING**  
**HADAPSAR**

**MOVE UP TO DELIGHTFUL RESIDENCES  
THAT PROVIDE**

**VALUE AND PRODUCT  
APPRECIATION**

PRESENTING  
**DELIGHTFUL HOMES**

AT

**HAPPENING  
ADAPCAR**

CLOSER  
TO LIFE

# DELIGHTFUL PRESIDENTIAL SUITES





East

**BUILDING B2 WING A - TYPICAL FLOOR PLAN**



**FOR INTERNAL USE ONLY**

## BUILDING B2 WING A- PRESIDENTIAL SUITE (SERIES 01, 02)

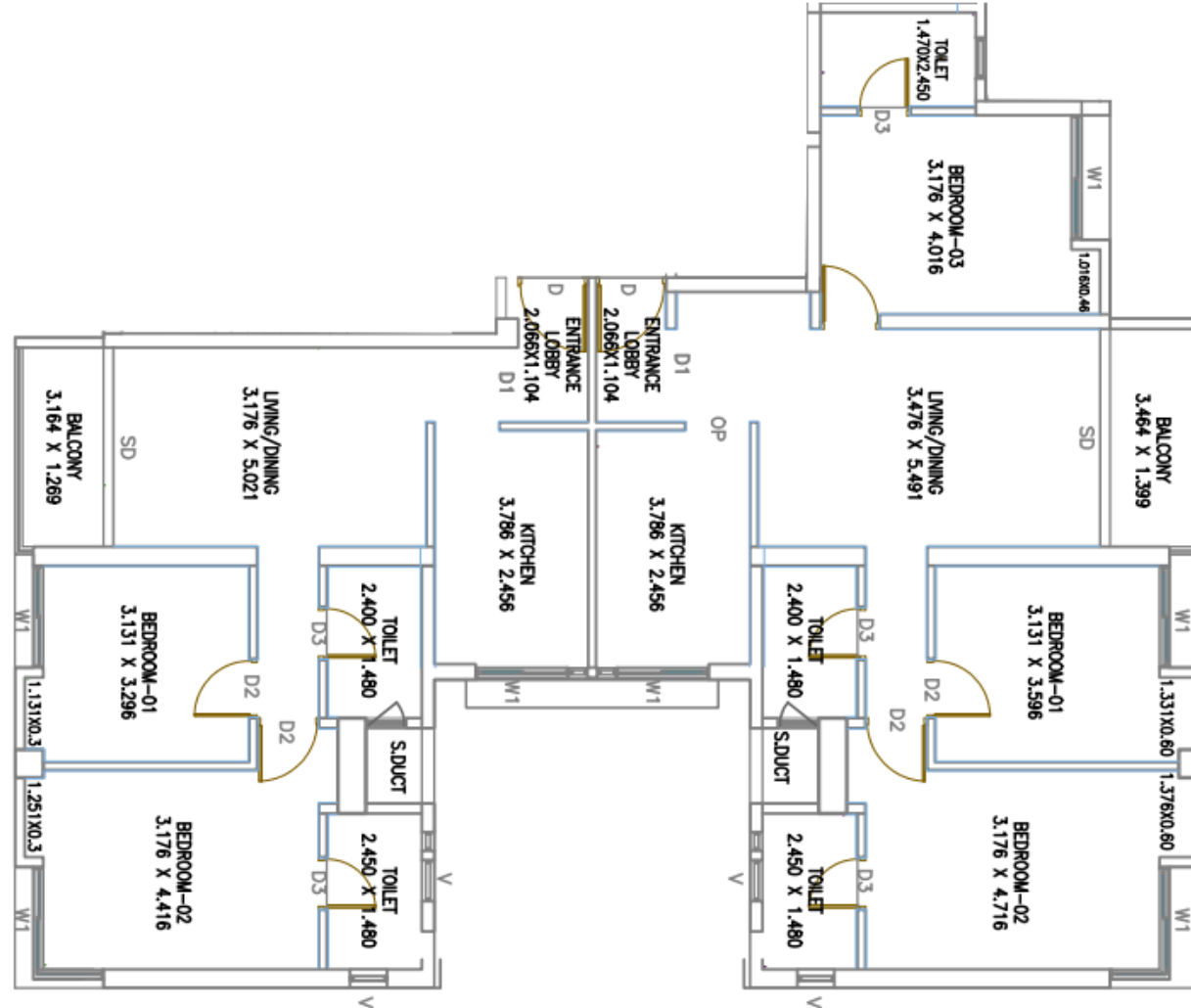

**FOR INTERNAL USE ONLY**



## BUILDING B2 WING A- PRESIDENTIAL SUITE (SERIES 03, 04)

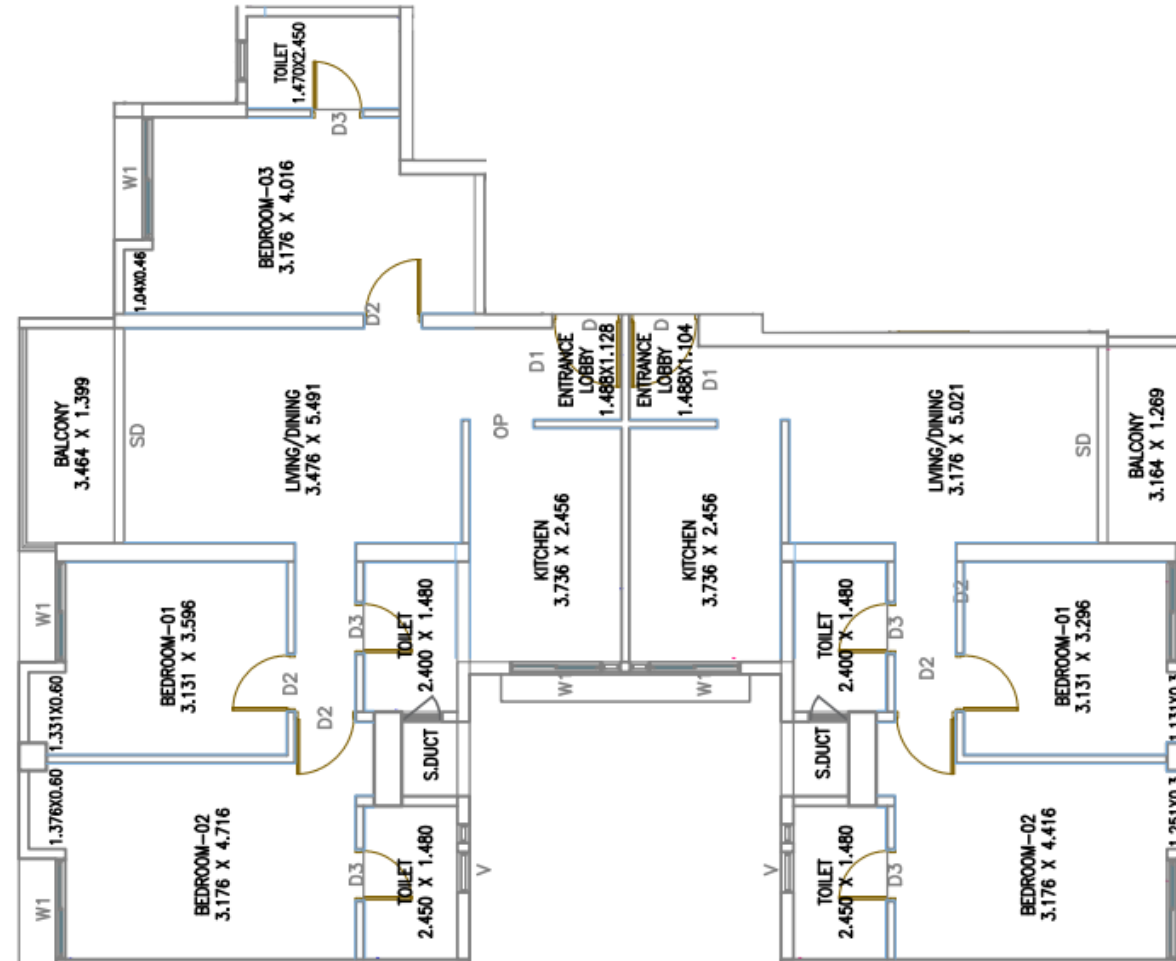

**FOR INTERNAL USE ONLY**

